

NTD

NATIONAL TRACKED DUMPER HIRE LTD

2.5 TONNE RIGID

SPECIFICATION

All dimensions below were correct at time of print, E&OE.



MODEL: MST-300VD

4 CYLINDER, DISPLACEMENT: 2.2 LITRES

47PS / 35.4KW @ 2800RPM / EU Stage IIIB

FUEL TANK CAPACITY: 61 LITRES

BI-DIRECTIONAL SEAT POSITIONS

MACHINE WEIGHT: 2685KG • PAYLOAD: 2500KG

MAX TRAVEL SPEED: 9KPH

GROUND PRESSURE (UNLOADED): 4.2 PSI

GROUND PRESSURE (LOADED): 8.1 PSI

TRACK WIDTH: 350MM

DUMP BODY CAPACITY (STRUCK): 0.88M³

DUMP BODY CAPACITY (HEAPED): 1.58M³

The smallest in our range. The MST-300VD is ideal for small projects with restricted access. This model has drop sides, making this a good choice as a compact tool carrier.

A Bi-Directional seat system that dramatically reduces the amount of turning and reversing. This machine is a great choice for projects of any size with restricted space.

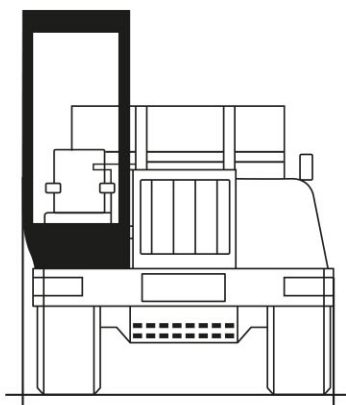

TOTAL WIDTH: 1745mm

TOTAL HEIGHT:
2330mm

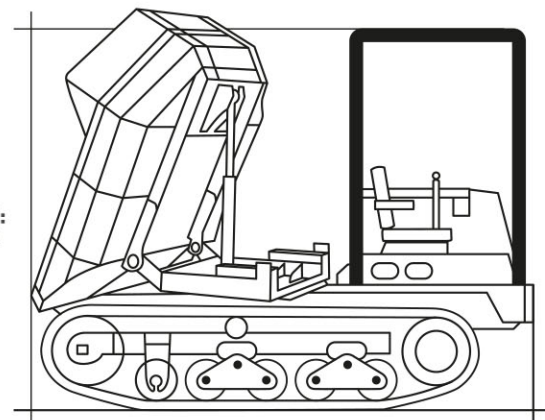

TOTAL LENGTH: 3510mm

FEATURE ICONS



HUMAN FORM
RECOGNITION SYSTEM



ROPS OPERATORS CAB



BIODEGRADABLE
HYDRAULIC OIL



HYDRAULIC
ISOLATION SYSTEM



SEATBELT BEACON
SYSTEM



REVERSING CAMERA



360° CAMERA



360° SLEWING

NTD National Tracked Dumper Hire Ltd, Weston Yard, Albury, Surrey GU5 9AF

0844 376 0051

hiredesk@ntdh.co.uk

www.ntdh.co.uk

