

NTD

NATIONAL TRACKED DUMPER HIRE LTD

5 TONNE RIGID

SPECIFICATION

All dimensions below were correct at time of print, E&OE.



MODEL: MST-800VD (up to 2017)

4 CYLINDER, DISPLACEMENT: 4.4 LITRES

131PS / 96.5KW @ 2200RPM / EU Stage IIIA

FUEL TANK CAPACITY: 130 LITRES

MACHINE WEIGHT: 6500KG

PAYLOAD: 4800KG

MAX TRAVEL SPEED: 11KPH

GROUND PRESSURE (UNLOADED): 3.1 PSI

GROUND PRESSURE (LOADED): 5.4 PSI

TRACK WIDTH: 600MM

DUMP BODY CAPACITY (STRUCK): 1.77M³

DUMP BODY CAPACITY (HEAPED): 2.9M³

Flat body and drop down sides makes this machine a great carrier tool as well as a tip body dumper. Low ground pressure and great payload ability combined with a large fuel tank and good tracking speeds make this mid-sized tracked dumper a popular choice for many sites. **Optional towing hitch available.**

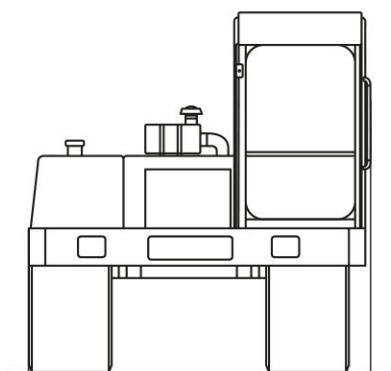

TOTAL WIDTH: 2425mm

TOTAL LENGTH: 4480mm

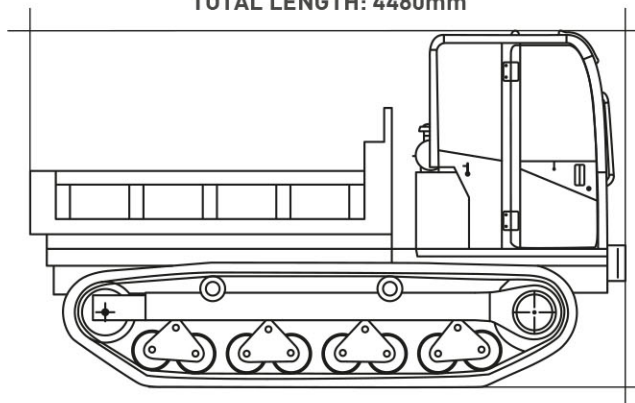

TOTAL HEIGHT: 2560mm

FEATURE ICONS



HUMAN FORM RECOGNITION SYSTEM



ROPS OPERATORS CAB



BIODEGRADABLE HYDRAULIC OIL



HYDRAULIC ISOLATION SYSTEM



SEATBELT BEACON SYSTEM



REVERSING CAMERA



360° CAMERA



360° SLEWING

NTD National Tracked Dumper Hire Ltd, Weston Yard, Albury, Surrey GU5 9AF

0844 376 0051

hiredesk@ntdh.co.uk

www.ntdh.co.uk

